

Chapter 1

Numbers 1

1A Comparing whole numbers

1 a < b > c > d >

2 5677, 5765, 6575, 6765, 7556, 7655

3 WA, Qld, NT, SA, NSW, Vic, Tas, ACT

4 Albany, Kalgoorlie, Newman, Eucla, Broome, Derby

1B Comparing and ordering decimals

1 a 13 b 14.05 c 0.6 d 1.02

2 a true b false c false d true

e false f true

3 a B b C c B d C

e A f C

1C Comparing and ordering fractions

1 a $\frac{1}{2}$ b $\frac{4}{5}$ c $\frac{4}{10}$ d $\frac{4}{11}$

2 a true b true

3 $\frac{4}{5}, \frac{7}{9}, \frac{18}{15}, \frac{2}{3}, \frac{13}{20}$

4 Peter as $\frac{2}{3} > \frac{3}{5}$

1D Comparing directed numbers

1 a 2°C b -7°C c 0°C d -4°C

e -9°C, 20°C (for example)

f -14°C, -33°C (for example)

2 a > b < c > d <

e < f > g < h >

3 a -6, -5, -3, -2, -1

b -821, -392, -5, -3, 428

Numbers 2

1E Calculating with decimals

1 a 14.1 b 0.65 c 6.66

2 a 0.016 b 8.892 c 0.201 d 0.032

3 a 0.3 b 0.48 c 0.007 d 33

4 a 3.56 b 2.4 c 0.28

5 \$18.25 6 \$43.25 7 \$33.65

8 a 3.25 m b 1.23 m

9 Total cost of adult's tickets = $6 \times 19.75 = \$118.50$

Total cost of children's tickets = $\$185.30 - \$118.50 = \$66.80$

Cost for each child = $\$66.80 \div 8 = \8.35

1F Calculating with fractions 1

1 a $\frac{4}{5}$ b $\frac{3}{5}$ c $\frac{4}{5}$ d $\frac{1}{2}$

e 1 f $\frac{1}{5}$

2 a $\frac{13}{15}$ b $\frac{7}{10}$ c $\frac{19}{24}$

3 a $\frac{1}{12}$ b $\frac{5}{8}$ c $\frac{13}{30}$

4 a $\frac{2}{9}$ b $\frac{2}{13}$ c $\frac{8}{5} = 1\frac{3}{5}$ d $\frac{1}{9}$

Numbers 3

1F Calculating with fractions 2

1 a $2\frac{2}{3}$ b $6\frac{3}{8}$ c $2\frac{7}{11}$

2 a $\frac{9}{2}$ b $\frac{12}{5}$ c $\frac{73}{10}$

3 a $3\frac{1}{2}$ b $\frac{4}{5}$ c $4\frac{1}{6}$

4 $\frac{9}{40}$ 5 $\frac{3}{5}$

6 a Year 10 b $\frac{1}{30}$ 7 $\frac{3}{10}$

8 450 9 4.5 ha 10 25 hours

11 a $7\frac{1}{2}$ b $\frac{9}{10}$

1H Dividing fractions

1 a $\frac{2}{7}$ b $\frac{10}{3}$ c 5 d $\frac{1}{6}$

2 a $\frac{8}{15}$ b $\frac{1}{2}$ c 8 d $\frac{1}{16}$

e $\frac{1}{2}$ f $2\frac{4}{7}$

3 $1\frac{3}{4}$ reams 4 $\frac{11}{20}$ 5 25 days

Numbers 4

1I Calculating with directed numbers

1 a -6 b 2 c -3 d -18 e -6 f 2

2 a 6 b -10 c 1 d -4 e -1 f -17

3 a -42 b 4 c -80 d -45 e 8 f -90

4 a -5 b 7 c -5 d -9 e -1 f 6

5 a -12 b -17 c 24 d 6 e 25 f 20

g -12 h 7

6 -5°C

1K Interpreting and evaluating indices

1 a 6^3 b $(-4)^6$

2 a 64 b 169 c 2401 d -512

3 a 1.4641 b 49 c 128 d 121

4 a 0 or some other value (depends on how the calculator orders the operations or how the problem is keyed into the calculator).

b 0

1M Percentages

1 a 20% b 28%

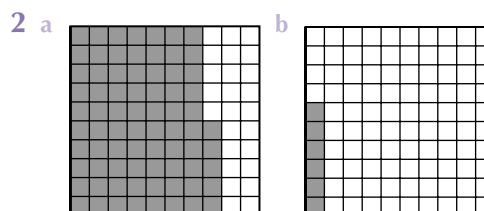

Homework Book Answers

3 a 50% b 25% c 40% d 85% e 15%

4 a 7%, 17%, 49%, 53%, 70%

b $6\frac{1}{2}\%$, 9%, 12%, $33\frac{1}{2}\%$

5 55% **6** <32% as some journeys may have been by sea or by combined methods of transport.

Numbers 5

1N Percentages to fractions

1 a $\frac{17}{100}$ b $\frac{3}{10}$ c $\frac{99}{100}$ d $\frac{49}{100}$

e $\frac{3}{4}$ f $\frac{1}{5}$ g $\frac{1}{100}$ h $\frac{1}{20}$

i $\frac{3}{50}$ j $\frac{3}{5}$

2 a $\frac{1}{8}$ b $\frac{1}{6}$ c $\frac{9}{400}$

3 a $\frac{19}{25}$ b $\frac{6}{25}$

1O Fractions to percentages

1 a 40% b 70% c 59% d 12%

e 25% f 35%

2 a 33·33% b 44·44% c 42·86% d 83·33%

3 8·5% **4** 37·5%

5 a 55%, 80%, 54%, 48% b Fractions

c Angles

d Assume the tests are equally difficult.

1P Percentages to decimals

1 a 0·5 b 0·29 c 0·04 d 1·25 e 0·692

2 Type O: 0·39; Type AB: 0·02

3 a 0·197 b 0·197 litres

1Q Decimals to percentages

1 a 53% b 30% c 1%

d 70% e 64·9% f 156%

2 120% **3** 53%

Puzzle

The three cards Queen of Hearts, King of Hearts and King of Clubs are in sequence from left to right.

Chapter 2

Consumer Maths 1

2A Calculations in business

1 \$22·50 **2** \$44·40 **3** \$18·55

4 \$1·75 **5** \$138·50 **6** \$9·55

7 \$2·40

8 a Company Y b 10 cents

9 a \$232·95 b \$79·05

10 \$7·45

2C Finding percentages of quantities

1 a 41·44 kg b \$185 c 240 m d \$8556

2 304

3 a \$17·89 b \$101·36 (\$101·35)

4 a \$2600 b \$7300 c \$17 500

2D Expressing quantities as a percentage

1 a 56% b 60% c 48·3%

Consumer Maths 2

2E Discount

1 a \$810 b \$110·40 c \$2·63

2 a \$408 b \$768 c \$2102·40

3 \$67·50

4 A: $1300 - 0·35 \times 1300 = \845

B: $1150 - 0·2 \times 1150 = \920

Refrigerator A is cheaper.

5 a \$28 b 40%

6 a 20% b 3·8%

2G Percentage change

1 a \$1080 b 44·94 kg

2 a 409·6 seconds b \$3900

3 \$10·35 **4** \$190·80

5 22·6%

6 \$400 → \$440 → \$396

Difference is \$4

7 \$114·37 (\$114·35 for cash)

8 a \$103·90 b 32·8%

Puzzle

13·3%

Consumer Maths 3

2H Commission

1 a \$4200 b \$1875 c \$234 500

2 \$4500 **3** \$193·30

4 \$1142·50 **5** \$15 000

Investigation: Same amounts but different percentages

1 25% **2** 20%

3 The answers—25% and 20%—are different because the increase and decrease of 50 members are calculated as percentages of different amounts.

Puzzle

16 coins

2I Wages and tax scales

1 a \$838 b \$20·95

2 a \$630 b \$30 240 (plus 4 week's holiday pay of \$2520).

3 a \$24 580·50 b \$11 125 c \$2235·50

4 a \$1478·75 (calculated from the data in the table)
c \$287·25

5 a \$8211 b $\$375·87 + \$123·17 = \$499·04$
(The figure \$123·17 is based on 1·5% of the full \$8211 and not \$2211.)

c \$430·96 refund (according to the calculation in part b above)

Consumer Maths 4

2J Simple interest

- 1 a \$720 b \$12 000
 2 \$60
 3 a \$2400 b \$6400
 4 \$121 500
 5 a \$270 b \$3840
 c 8% d 2.5 years

2K Finding the rate of interest

- 1 a 6% b 12% c 2% d 7%
 2 3.5%
 3 a 8.47%, 0.71% b 8.48%, 0.71%
 4 a 0.746% b 8.95%

Puzzle

Caterina: 2001; Edward: 1983

2L Best buy

- 1 E, D, B, C, A
 2 Cinema A, because each ticket costs \$6. For cinema B, each ticket costs \$6.25
 3 a 500 g
 b $2.29 \div 250 \times 100 = \$0.916 = 91.6$ cents

Chapter 3

Measurement 1

3A Conversion of measurement units

- 1 a 0.5 ha b 5 g c 1 litre d 20 mL
 e 200 mm f 500 m² g 2 kg h 10 cm
 2 Mass = 2830 g, length = 523 cm
 3 a 8 km b 42 000 mg c 375 mL
 d 310 kg e 5.8 cm f 738.5 cm
 4 40 cm 5 $13\frac{1}{3}$ bags
 6 a They alternate—the 1000 kWh and 10 kWh pointers move clockwise, the 100 kWh and 1 kWh pointers move anti-clockwise.
 b 8729 kWh c 67
 7 2 litre, 600 mL, 1 litre 8 0.17 mm

3B Perimeter of shapes

- 1 a 28 cm b 36 cm
 2 a 16 cm b 26 cm
 c d

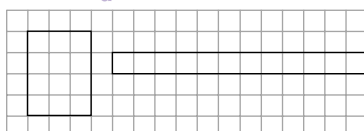

3 a

Side length	Area	Perimeter
2 cm	4 cm ²	8 cm
5 cm	25 cm ²	20 cm
6 cm	36 cm ²	24 cm
8.4 cm	70.56 cm ²	33.6 cm
7 cm	49 cm ²	28 cm

Side length	Area	Perimeter
10 cm	100 cm ²	40 cm
12 cm	144 cm ²	48 cm

- b 4 cm
 4 a 40 cm b 30 cm
 c perimeter of rectangle = $\frac{3}{4}$ perimeter of square
 5 68 m

Measurement 2

3C Circumference of circles

- 1 a radius b arc c diameter
 2 a 50.27 cm b 32.04 m c 37.70 mm
 3 6.685 cm
 4 a 9 cm b 10.66 m
 5 because $d = 2r$ (diameter is twice the length of the radius)
 6 No, the paper is not large enough if the tube is placed at right-angles to the paper before wrapping. To cover the ends of the container, the paper would need to be at least $(4 + 25 + 4)$ cm long—i.e. 33 cm in length, but the longest measurement of the paper is only 32 cm. If the tube is placed on a diagonal (41.2 cm long) and then rolled there will be overlapping leaving some parts of the container uncovered. Although the area of the paper (832 cm²) is larger than the surface of the container the paper would have to be cut to cover the surface.
 7 a 31 m
 b The value of the diameter used is not accurate. The diameter of the hose loop increases as the hose forms layers of loops in the well of the reel. (The loops are helical rather than circular.)

Investigation: Lassoing the Earth

The gap would be 1.27 m.

3D Area 1

- 1 a m² b km² c mm²
 d ha e ha f cm²

2

	mm ²	cm ²	m ²
a	550 000	5500	0.55
b	67 500 000	675 000	67.5
c	400 000	4000	0.4

Measurement 3

3D Area 2

- 1 a 640 000 m² b 2.15 ha c 400 mm²
 d 300 ha e 60 cm²

2

	m ²	ha	km ²
A	3 450 000	345	3.45
B	75 000 000	7500	75
C	200 000	20	0.2

- 3 a 12 cm² b 9 cm² c 300 cm²
 d 24.01 cm² e 42.88 cm² f 10.35 cm²

Homework Book Answers

- g 15 cm² h 49.88 cm²
4 a 140 m² **b** 48 cm²
5 24 cm² **6** 4.8 cm **7** 80 m²

Investigation: The soccer field

The outside lines measure $100 + 50 + 100 + 50 = 300$ m

The halfway line measures 50 m

The goal areas measure $2 \times (10 + 15 + 10) = 70$ m

Total length of lines = $300 + 50 + 70 = 420$ m

Area of lines in m² = $420 \times 0.04 = 16.8$ m²

Amount of paint needed = $\frac{16.8}{2} = 8.4$ litres.

A 10-litre bucket of paint would be sufficient.

3F Area of trapeziums

- 1 a** 15 cm² **b** 99 cm² **c** 102 cm² **d** 190 cm²
2 a Both combined areas are triangles with the same base and an equal height.
b A and C
3 43 m²

Measurement 4

3H Area of circles and sectors

- 1 a** 50.27 cm² **b** 111.2 m²
2 a

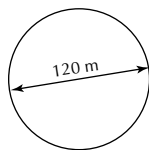

- b** 11 300 m²
3 a 23.43 m² **b** 102.5 m²

3I Total surface area of prisms

- 1 a** 126 cm² **b** 36 cm²
2 204 cm² **3** 64 m²
4 a rectangle
b Because the cut exposes wood which originally was not on a surface.
c 2000 cm²
5 4.64 m²

Puzzle

0123:45

3J Surface area of pyramids

- 1** 56 cm²
2 433 000 mm²

Measurement 5

3K Volume

- 1 a** 12 cm³ **b** 120 cm³
2 125 cm³
3 1.8 m
4 288 dice
5 a 4.5 m³ **b** 4050 kg
6 225 m³
7 a 150 cm³ **b** 384 m³

- 8 a** 75 cm³ **b** 240
9 \$216 000

Puzzle

6 cm by 8 cm by 12 cm

3L Capacity

- 1 a** 5000 cm³ **b** 750 cm³ **c** 200 mL
d 54 litres
2 9 litres
3 a 8 kg **b** 650 g
c 1.25 kg = 1250 g
4 10.29 cm
5 30

Chapter 4

Pythagoras 1

4A Exploring Pythagoras' Theorem

- 1** Yes. The distance along the wall is 15 m, and the line is at an angle to the wall.
2 More than 15 m and less than 20 m.
3 The length is 17 cm which represents 17 m.
4 Yes, because it will probably sag a bit.
5 $289 = 8^2 + 15^2$
6 From the careful scale drawing of the right-angled triangle the side marked x has a length of 5 cm.
7 5 cm **8** $x = \sqrt{3^2 + 4^2}$

4B Stating Pythagoras' Theorem

- 1 a** $r^2 = p^2 + q^2$
b $e^2 = d^2 + f^2$
c $q^2 = p^2 + r^2$
2 a $c = \sqrt{625} = 25$
b $c^2 = 25 + 81$
 $c^2 = 106$
 $c = \sqrt{106} = 10.30$
c $c^2 = 121 + 169$
 $c^2 = 290$
 $c = \sqrt{290} = 17.03$ (4 sf)

4C Finding the length of the hypotenuse 1

- 1 a** 10 cm **b** 9.2 cm **c** 34 cm **d** 4.2 cm
e 48.5 cm **f** 101 cm **g** 0.85 cm **h** $8\frac{1}{3}$

Pythagoras 2

4C Finding the length of the hypotenuse 2: Applications

- 1** 3.93 m
2 a

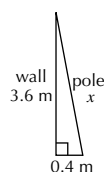

- b 3.622 m
3 11.66 m

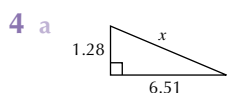

- b 6.63 m
5 9.5 m
6 a 125 m b 45 m

Investigation: The ants and the sugar bowl
7.810 m

4D Pythagorean triples

- 1 Triangle C is right angled: $14^2 + 48^2 = 50^2$ —that is, $196 + 2304 = 2500$

Investigation

- 1 Because the sum of the squares of the first two numbers is equal to the square of the last number.
2 Each number in the triple has been multiplied by the same value – here by 2 and also by 8.
3 (first number)² = second number + third number
4 $x^2 = y + y + 1$
 $2y = x^2 - 1$
 $y = \frac{x^2 - 1}{2}$

- 5 Yes

Pythagoras 3

4E Finding the length of a shorter side

- 1 a 3 cm b 3.5 cm c 24 cm
d 24.3 cm e 2.3 cm f $3\frac{3}{8}$
2 a In the second and third lines x should be x^2 , and then in the 4th line the student needs to calculate the square root of 0.63
b 0.79 m

- 3 a  b 3.425 m

- 4 6.3 m (2 sf)

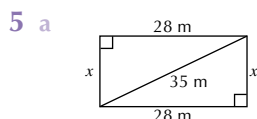

- b 98 m

4F Mixed problems

- 1 a $x = \sqrt{29}$ b $x = \sqrt{90} = 3\sqrt{10}$
2 a $x = \sqrt{3}$ b $x = \sqrt{125} = 5\sqrt{5}$
3 $x = 18\sqrt{34}$ cm

Pythagoras 4

4G Composite shapes

- 1 a 8.60 m b 22.20 m
2 a $x = 12$ cm, $y = 5$ cm
b $x = 9$ m, $y = 41$ m
3 a 4.47 m b 4.72 m

4H Extension: Co-ordinate geometry

- 1 a 5 units b 1.41 units c 13 units
2 8.062 km ($\sqrt{65}$ km)

Extension: Pythagoras in three dimensions

- 1 a  b 15 cm

- c  d 17 cm

- 2 a 14.14 cm b 17.32 cm
3 a 25 cm b 60 cm

Chapter 5

Trigonometry 1

5A Labelling a right-angled triangle

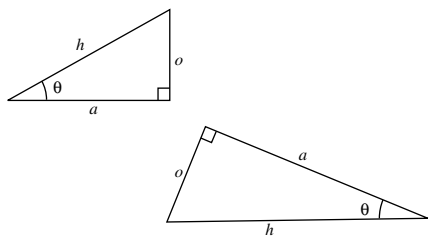
- 1 a 

2

Triangle	Hypotenuse	Opposite side	Adjacent side
$\triangle ABC$	AB	BC	AC
$\triangle DEF$	DF	EF	DE
$\triangle GHI$	GI	GH	HI

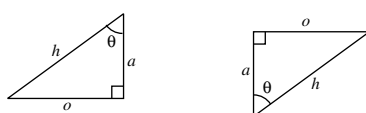
- 3 a 

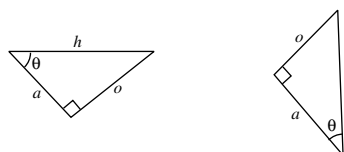

Homework Book Answers

5B Exploring the tangent ratio

Triangle	o	a	$\frac{o}{a}$
1	15	26	$\frac{15}{26} = 0.577$
2	17	30	$\frac{17}{30} = 0.567$
2	12	21	$\frac{12}{21} = 0.571$
4	21	36	$\frac{21}{36} = 0.582$

- 2 The ratio is the tangent ratio for the angle 30° . It measures between 0.56 and 0.58. **3** 0.577

5C Using the tangent ratio

- 1 a 3.464 b 6.114 cm
 2 a 36.9° b 53.1°
 3 4.3 m 4 56.3°

Trigonometry 2

5F Extension: Finding the opposite side

- 1 a 0.7314 b 0.1045 c 0.9816 d 0.7046
 2 a 3.01 cm b 5.35 m c 1.63 m d 20.86 m
 e 32.36 cm f 1.36 m
 g 28.38 cm h 477.11 mm
 3 The height of the tent pole is 2.16 m.
 4 The car's height above sea level has increased by 93.86 m/
 5 The width of the shelf is 12.73 cm.
 6 The high end of the see-saw is 1.21 m above the ground.

Investigation: The cosine ratio

Triangle	o	h	$\frac{o}{h}$
1	32	41	$\frac{32}{41} = 0.78$ (2dp)
2	48	62	$\frac{48}{62} = 0.77$ (2dp)
3	21	28	$\frac{21}{28} = 0.75$ (2dp)
4	50	65	$\frac{50}{65} = 0.77$ (2dp)

- 2 The cos ratio for the angle 40° measures between 0.75 and 0.78.
 3 0.7660

Trigonometry 3

5G Extension: Finding the adjacent side

- 1 a 0.1045 b 0.5000 c 0.9994 d 0.8526
 2 a 4.49 cm b 6.78 cm c 11.33 cm d 19.32 m
 e 56.17 m f 161.90 mm
 3 5.955 m 4 40 mm 5 36.96 m

5H Extension: Finding the hypotenuse

- 1 a 24.89 b 26.94
 c 8.98 d 97.07

- 2 a 23.58 cm b 16.69 m
 c 9.15 km d 173.39 mm

Trigonometry 4

5H Extension: Finding the hypotenuse 2—Applications

- 1 12 cm 2 15.2 m
 3 7 km 4 176 mm

5I Extension: Angles using sine and cos

- 1 a 45.5° b 60.6°
 c 82.8° d 15.3°
 2 a 23.6° b 41.4° c 44.9° d 65.3°
 3 a

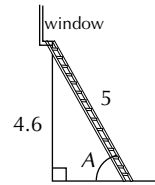

- b Using $\text{Sin}^{-1} \frac{4.6}{5}$ to give A, $A = 67^\circ$. The ladder is safely placed as far as the warning goes.

5J Extension: Elevation and depression

- 1 a

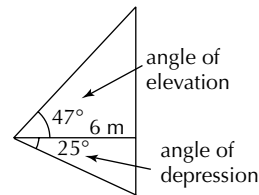

- b 9 m

Trigonometry 5

Extension: Choosing the correct trigonometry formula

- 1 a tan b cos
 c sin d cos
 2 a 5.27 m b 14.42 m
 3 a 12.6 cm b 31.1 m
 c 67.4° d 46.2°
 4 a

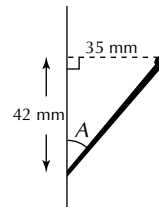

- b 40°
 5 a $32.9 \text{ m} + 67.4 \text{ m} = 100.3 \text{ m}$
 b 25.3 m

5K Extension: Trigonometry and bearings

- 1 544 m
 2 1608 m

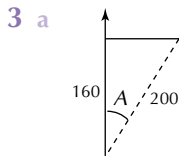

b 037°

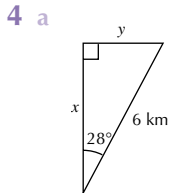

b 5.3 km

c 2.8 km

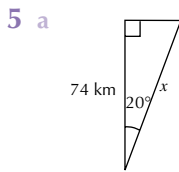

b 79 km

Chapter 6

Rates and Ratios 1

6A Ratio and proportion

1 a 2 : 5 **b** 18 : 11 **c** 4 : 75

d 6 : 5 **e** 8 : 5

2 a 9 : 8 **b** 6 : 17 **c** 8 : 23

6B Simplifying ratios

1 a 3 : 5 **b** 1 : 3 **c** 2 : 5 **d** 9 : 8

e 1 : 4 **f** 3 : 4 **g** 2 : 1 **h** 5 : 7

2 a 3 : 2 **b** 3 : 8 **c** 1 : 3 **d** 3 : 4

e 2 : 3 **f** 3 : 5

3 a 3 : 5 **b** 4 : 5 **c** 1 : 2 **d** 8 : 7

4 a 7 : 3 **b** 5 : 1 **c** 5 : 4 **d** 3 : 1

e 3 : 8 **f** 1 : 5

5 **a** 3 : 14 **b** 6 : 5 **c** 1 : 6 **d** 10 : 1

7 a 2 : 3 **b** 6 : 5 **c** 1 : 6 **d** 10 : 1

e 3 : 14

8 4 : 1 **9** 3 : 7 **10** 1 : 19

6C Finding quantities using ratios 1

1 350 girls

2 a 15 litres of milk **b** 4.8 litres of cream

Rates and Ratios 2

6C Finding quantities using ratios 2

1 a $x = 1$ **b** $x = 36$ **c** $x = 8$ **d** $x = 10$

2 a 350 g **b** 500 g **3** 4%

4 Pizzas with olives: 73%

Pizzas without olives: 27%

6D Sharing using ratios

1 a \$20, \$30 **b** 15 kg, 25 kg **c** 22 cm, 66 cm

d \$8, \$4 **e** 500, 2000 **f** \$40-80, \$27-20

2 a 5 hours **b** 20 hours

3 28 **4** \$80

5 240 mL of oil, 960 mL of petrol

6 35 minutes **7** \$168

6E Rates

1 Speed of a car: 80 km/h

Wage rate: \$18 per hour

Petrol consumption: 8 L/100 km

Cost of building: \$1800/m²

2 \$60

3 a 17 mL per minute **b** 680 mL

4 a 84 litres **b** 75 km

5 a 75 **b** 16 minutes

c 900 **d** 900 pieces per hour

6 a \$60 **b** \$165 **c** 7.5 m

7 a \$75 / m² **b** \$67 500 **c** 640 m²

8 a 20 minutes **b** 105 litres

Rates and Ratios 3

6F Using rates: Speed, distance and time

1 74 km/h **2** 20 km/h **3** 8 km **4** $6\frac{1}{2}$ hours

5 a night time **b** 15 minutes **c** 380 km

d $200 \text{ km} \div 2.5 \text{ hours} = 80 \text{ km/h}$

e 90 km/h **6** 18 km

Puzzle

2 minutes

6G Graphs and time 1

1 a 6 km **b** 65 minutes **c** 30 minutes

d The graph shows Chris stopped for 10 minutes on the way home, so this must be where the puncture took place.

e The graph is steeper for the part that shows Chris cycling to town.

2

The Pearson family's motorway journey

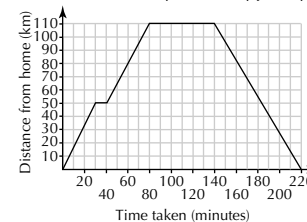

Rates and Ratios 4

6G Graphs and time 2

1 a

Time	Distance from Kalgoorlie	
	Kelly	Kaye
0800	0	600
0900	75	600
1000	150	600
1100	225	500
1200	300	400
1300	375	300

Homework Book Answers

Time	Distance from Kalgoorlie	
1400	450	200
1500	525	100
1600	600	0

b

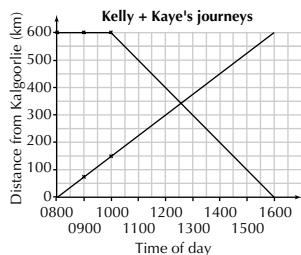

c 12:30 pm. This is the time where the lines cross on the graph.

d On passing they are closer to Perth.

2 a

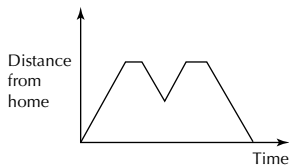

b

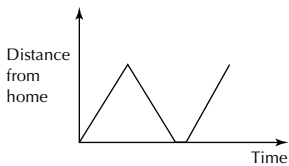

6H Scale diagrams

1 a 1200 cm = 12 m b 1140 cm = 11.4 m

c 360 cm = 3.6 m d 2.4 cm

e 2 cm f 0.5 cm

2 a 38 km b 14.4 km

c 13 km d 4.5 cm or 45 mm

e 15 cm or 150 mm f 9.1 cm or 91 mm

3 a 4.5 cm by 2.5 cm or 45 mm by 25 mm

b 54 m by 30 m

c There are 18 spaces along one side of the car park, which is 54 m. Width of one space is $54 \text{ m} \div 18 = 3 \text{ m}$

4 1.85 mm

5 a 135 cm or 1.35 m b 285 cm or 2.85 m

c

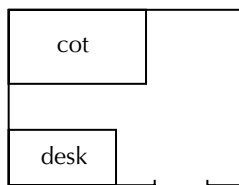

6 a About 215 km b 55 to 60 km

Chapter 7

Polygons and Polyhedra 1

7A Angles revision

1 1 = \hat{EFG} or \hat{GFE}

2 = \hat{DEF} or \hat{FED}

3 = \hat{IHL} or \hat{IHK} OR \hat{KHI} or \hat{LHI}

4 = \hat{IJK} or \hat{KJI}

5 = \hat{HIJ} or \hat{JIH}

6 = \hat{BAG} or \hat{GAB} (other answers are also possible)

7 = \hat{DGF} or \hat{FGD} (other answers are also possible)

8 = \hat{ABC} or \hat{CBA}

2 a 9 b 11 c 10 d 10

3 b 10 c 4 d 10

4 a $b = 52^\circ$ b $c = 76^\circ$

5 a 50° b 81° c 19° d 56° e 0°

6 $q = 44^\circ$ 7 a $a = 152^\circ$ b $c = 60^\circ$

8 a 100° b 75° c 106° d 46° e 90°

9 a True b True c False

d False e True f False

10a $a = 290^\circ$ b $d = 80^\circ$ c $e = 130^\circ$

d $h = 115^\circ$ e $j = 100^\circ$ f $n = 95^\circ$

11a 311° approximately b 268°

Polygons and Polyhedra 2

7B Angles and parallel lines

1 a corresponding b alternate

c vertically opposite d corresponding

e co-interior

2 a alternate angles on parallel lines; $a = 53$

b co-interior angles on parallel lines; $b = 92$

c vertically opposite angles; $c = 71$

d corresponding angles on parallel lines; $d = 137$

3 a $x = 38^\circ$, $y = 57^\circ$ b $x = 50^\circ$, $y = 45^\circ$

c $x = 37^\circ$, $y = 67^\circ$ d $x = 72^\circ$, $y = 68^\circ$, $z = 40^\circ$

4 a $x = 81^\circ$ b $x = 143^\circ$

7D Polygon facts

1 360° 2 720°

3 a 24° b 156°

c (\angle 's on line)

4 a $n = 36$

b the polygon has 36 sides

5 a $x = 99^\circ$ b $x = 76^\circ$

c $x = 76^\circ$ d $x = 88^\circ$

6 24 sides

7 equilateral triangle

8 36°

Polygons and Polyhedra 3

7E Congruent shapes

1 a $\angle PSQ = \angle PRQ$ (both = 40°)

$\angle SPQ = \angle RQP$ (both = 110°)

$PQ = PQ$ (common)
This fits the test ASA

b ΔPTS

2 $x = 2, \theta = 53^\circ$

3 9

7F Similar figures

1 a 58° b $\angle B$

2 a ΔABC and ΔGHI b $\angle I$

3 a 2 b $\frac{1}{4}$

7H Similar triangles

1 ΔDEF and ΔHGI

2 A and C

3 a ΔPSR

b $\frac{PQ}{PS} = \frac{QS}{SR} = \frac{PS}{PR}$

4 a $\frac{AB}{FE} = \frac{BC}{ED} = \frac{CA}{DF}$

b $x = 10.5, y = 12.25$

Polygons and Polyhedra 4

7I Applying similar triangles

1 16 m

2 The width of the road is $(8 \cdot 25 - 3) 5.25$ m.

7J Exploring 3D shapes

	Faces	Edges	Vertices
Cuboid	6	12	8
Tetrahedron	4	6	4
Pyramid	5	8	5

2

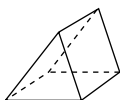

3 isosceles triangles

4

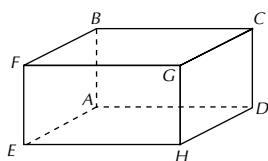

7K Drawing in 3D

1 a

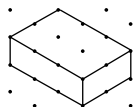

b

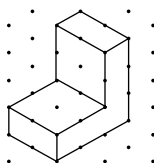

2 a 5

b 21

3

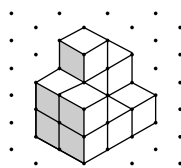

4

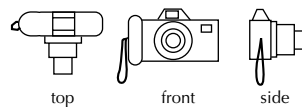

5

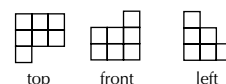

Chapter 8

Transformations and Location 1

8B Translation

1

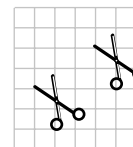

2 a

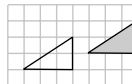

b

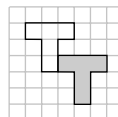

3 a 1 unit to the left and 2 units up

b 0 units sideways and 3 units down

c 2 units to the right and 0 units up or down

d 4 units to the left and 3 units up

8C Reflection

1

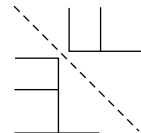

2

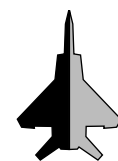

3 p

Homework Book Answers

4 a

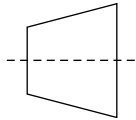

b trapezium

5 a D

b i 8 cm ii 5 cm

c 110°

8D Rotation

1 a

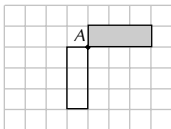

b

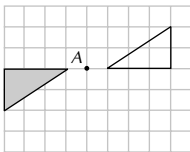

c

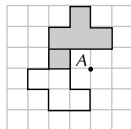

d

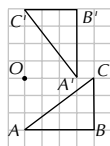

2 a G

b G

c 90° anti-clockwise

3 a

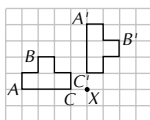

b 90° clockwise

4 a C

b $\{72^\circ, 144^\circ, 216^\circ, 288^\circ, 360^\circ\}$

5 a reflection

b rotation

Transformations and Location 2

8E Enlargement and reduction

1

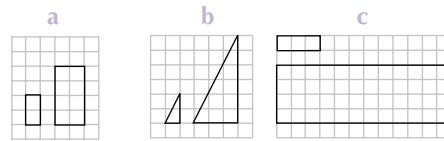

d

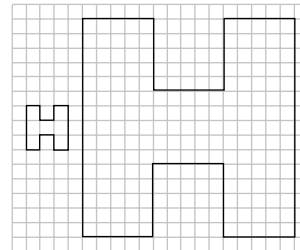

e

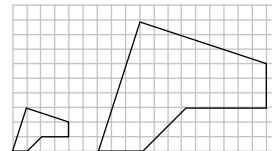

f

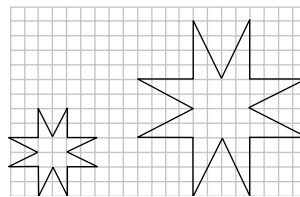

2

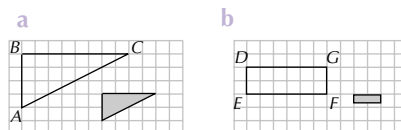

c



d

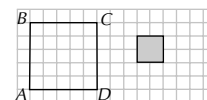

e

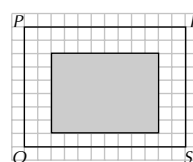

f

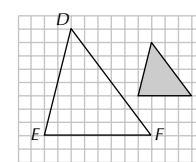

3 1.5 (1 dp)

4 113 mm by 85 mm

8F Exploring similar areas and volumes

- 1 The scale factor for length is 1.25.
The area of the image is 337.5 cm^2 .
- 2 8.1 m^2 3 52 cm^2
- 4 a $\frac{6}{4}$ b 16
- c $1.5^3 = 3.375$ d $3.375 \times 16 = 54$
- 5 a 1.4 b 686 mL

Transformations and Location 3

8H Drawing networks

1

Arcs	2	8	2
Vertices	3	7	2
Regions	1	3	2

2

	No. of regions (r)	No. of arcs (a)	No. of vertices (v)	$r - a + v$
a	6	12	8	2
b	7	15	10	2
c	4	18	16	2

3 $r - a + v = 2$ or $r + v = a + 2$ etc

4 116 arcs

5 a

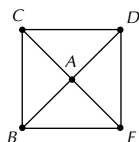

b B, C, D, E c A d arc, region

6 a yes

b no

7 a

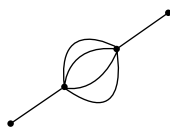
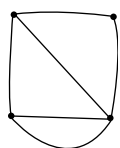

8 B, G

9 the octahedron is traversible

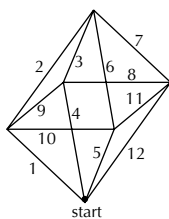

8I Using networks

1 a

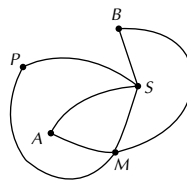

b vertices represent cities, arcs represent routes

c

	Number
Arcs	7
Regions	4
Vertices	5

2 L and J (in either order)

Investigation: Chemical storage

1 3

2 {B, C, D, F} {H, I, J} {A, E, G}

Chapter 9

Algebra and Number Patterns 1

9A Algebraic expressions

1 a $n = 31$ b $x = 11$ c $c = 7$

2 a 5 b 6 c 1

 d -1 e $\frac{1}{3}$

3 a $2x$ b $5y$ c $\frac{x}{6}$

 d pqr e $3xy$ f $\frac{4x}{y}$

 g $\frac{7}{x}$ h $\frac{2c}{5d}$ i $8xy$

 j $5xy$

4 a $x + 15$ b $\frac{x}{4}$ c $12x$

 d $2x - 3$

5 a $x - 10$ b $x + 50$ c $2x$

 d $\frac{x}{2}$

6 a $4x, 6x, 3x$ b $6p, -p$ c $ab, 3ab$

9B Adding and subtracting like terms

1 a $6x$ b $4x$ c $9x$ d $7p$

 e x f $-2x$ g $30p$ h $4x$

 i x

2 a $6x + 6y$ b $8x + 3$ c $14x + 3y$

 d $2x + 4y$ e $-2x + 3y$ f $3x - 2y$

 g $3x - 19$ h $11x + 1$ i $12 - 3x$

 j $-7x + 4$ k $-6x - 7$ l $8x - 9y$

 m $-8x - 6$

3 a $2pq$ b $9xy$ c $-7cd$

 d $10ab - 3bc + 11ac$

4 a $3x^2 + 8x$ b $7x^2 - 9x$ c $-x^2 + 6x - 1$

5 a $10x$ b $20x$ c $3x - 1$ d $7x + 20$

6 a $3p + 5p$ (other answers are possible)

 b $5x + y + x + 2y$ (other answers are possible)

 c $5x - 9 + 1$ (other answers are possible)

7 $8x + 3y$

Homework Book Answers

Puzzle

a

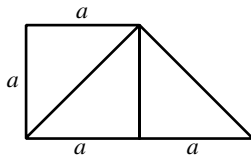

b $\frac{a^2}{2}$

c $\frac{3a^2}{2}$

Puzzle

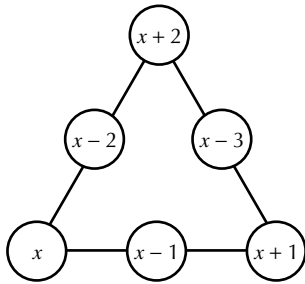

Algebra and Number Patterns 2

9C Multiplying and dividing terms

- 1 a $-4p$ b $6x$ c mn
 d $6p$ e $-12xy$
- 2 a $-6y$ b $30x$ c $-30xy$
 d $6xyz$ e $16x^2$
- 3 a $\frac{2}{3}$ b $\frac{-4}{x}$ c $\frac{3}{5y}$
 d $\frac{-1}{4y^2}$
- 4 a $-9p$ b $-2q$ c $\frac{4x}{3}$
 d $\frac{-4x}{3}$ e $\frac{x}{5}$
- 5 a $\frac{5p}{q}$ b $\frac{8x}{y}$ c $\frac{8a}{b}$
 d $\frac{-10p}{q}$
- 6 a $-6x$ b $\frac{-3p}{2q}$ c $2p$
 d $10x$ e $\frac{-4x^2}{3}$

9F Expanding single brackets

- 1 a $5(x+3) = 5 \times x + 5 \times 3 = 5x + 15$
 b $-2(4x+1) = -2 \times 4x + -2 \times 1 = -8x - 2$
 c $-8(3x-1) = -8 \times 3x - 8 \times 1 = -24x + 8$
- 2 a $6x + 12$ b $2x - 6$ c $-4x - 20$
 d $-3x + 18$
- 3 a $12x + 6$ b $12x - 10$ c $-20x + 4$
 d $-10x - 5$ e $-21x + 14$ f $30x + 24$
 g $10 + 20x$ h $-18 + 12x$ i $10 - 30x$
- 4 a $5x + 18$ b $6x + 6$ c $4x - 2$
 d $4x + 16$ e $13 - 2x$ f $12x - 21$
 g $-x + 2$ h $x - 3$ i $8 - x$
 j $2x - 6$
- 5 a $7x + 27$ b $-3x - 13$ c $4x + 13$
 d $-4x + 2$ or $2 - 4x$
 e $21x - 10$ f $10x + 2$ g $7x^2 - 6x^3$
 h $-2x^2 + 5x + 3$

- 6 a $(4x - 4)$ doors b $(12x - 12)$ hinges
 c $(5x - 4)$ handles

Algebra and Number Patterns 3

9G Expanding double brackets

- 1 a $x^2 + 6x + 8$
 b $x^2 + 12x + 11$
 c $x^2 + 3x - 28$
 d $x^2 + 5x - 24$
 e $x^2 - 7x + 10$
 f $x^2 - 2x - 80$
 g $x^2 - 13x - 68$
 h $x^2 - 17x + 72$
- 2 a $-x^2 + 4x + 32$
 b $-x^2 + 1$ or $1 - x^2$
 c $-x^2 + 4x - 4$
 d $6x^2 + 11x + 3$
 e $2x^2 - 9x - 5$
 f $3x^2 - 2x - 16$
 g $8x^2 + 2x - 1$
 h $-4x^2 + 5x + 21$
- 3 a $3x - 8$
 b $x^2 + 6x + 8$
 c $x^2 + x - 30$
 d $-4x - 30$
 e $1 - x - x^2$
 f $1 - x^2$
 g $3x^2 + 2x + 5$
 h $3x^2 + 17x + 10$

9H Expansions with patterns

- 1 a $x^2 - 25$
 b $x^2 - 49$
 c $x^2 - 121$
 d $81 - x^2$
 e $16x^2 - 1$
 f $4y^2 - 9$
- 2 a $x^2 + 10x + 25$
 b $x^2 - 2x + 1$
 c $x^2 + 16x + 64$
 d $x^2 - 24x + 144$
 e $4x^2 + 12x + 9$
 f $9x^2 - 30x + 25$
 g $25x^2 + 20x + 4$
 h $100x^2 - 20x + 1$

9I Factorisation: Common factors

- 1 a $6(x - y)$
 b $2(x + 2y)$
 c $5(x + 3)$
 d $4(4 - 3x)$
 e $12(2x + 1)$
 f $x(x - 3)$
 g $16(4x - 3)$
 h $5x(x + 3)$

- i $x^2y^2(y-1)$
 j $5(2x^2-1)$
2 a $(a+d)(b-c)$
 b $(x-y)(3+a)$
 c $2(2a-3b)(c+d)$
 d $(r-2s)(2p-3q)$

Algebra and Number Patterns 4

Extension: The difference of two squares

- 1 a** $(x+9)(x-9)$
 b $(x+8)(x-8)$
 c $(x+12)(x-12)$
 d $\left(x+\frac{1}{3}\right)\left(x-\frac{1}{3}\right)$
 e $(1+x)(1-x)$
 f $(12+11x)(12-11x)$
 g $(2p+5q)(2p-5q)$
 h $(x+9)(x-7)$
 i $(5x+12)(5x+8)$
 j $16(x-1)$

Extension: Perfect squares

- 1 a** $(x+4)^2$
 b $(x-9)^2$
 c $(x-3)^2$
 d $(x+16)^2$
 e $\left(x+\frac{1}{5}\right)^2$
2 a $(4x+3y)^2$
 b $(5x+1)^2$

Puzzle

Possible positions for the roads are as shown:

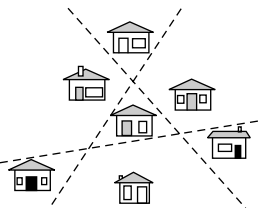

9J Factorising quadratic trinomials

- 1 a** $(x+2)(x+4)$
 b $(x+1)(x+4)$
 c $(x+1)(x-5)$
 d $(x+4)(x-5)$
 e $(x+10)(x-2)$
 f $(x-3)(x-5)$
 g $(x+3)(x-20)$
 h $(x-7)(x-8)$
 i $(x-10)(x-10)$ or $(x-10)^2$
 j $(x+20)(x-2)$
2 a cannot be factorised
 b $(x-8)(x+1)$
 c $(x-5)(x-8)$
 d cannot be factorised

- 3 a** $7(x+1)(x+5)$
 b $2(x+2)(x-2)$
 c $6(x-2)(x-1)$
 d $3(x+1)^2$
 e $4(x-5)(x+1)$
 f $3(x+3)(x-3)$
 g $5(x-2)^2$
 h $20(x-2)(x+1)$

Algebra and Number Patterns 5

9K Index numbers

- 1 a** 8^4 **b** 12^5 **c** 13^2 **d** $(-3)^5$
2 a $6 \times 6 = 36$ **b** $8 \times 8 \times 8 = 512$
 c $3 \times 3 \times 3 \times 3 \times 3 = 243$
 d $9 \times 9 \times 9 \times 9 = 6561$
3 a $1^3 = 1$ **b** $2^9 = 512$ **c** $9^2 = 81$
 d $10^4 = 10\,000$
4 a -32 **b** 1 **c** -1000 **d** 81
 e 16 **f** -125 **g** -256
5 a $x=3$ **b** $x=5$ **c** $x=6$ **d** $x=2$
6 a $x=7$ **b** $x=9$ **c** $x=6$ **d** $x=16$

9L Exploring index laws

- 1 a** $9 \times 243 = 2187 = 3^7$
 b $2187 \times 3 = 6561 = 3^8$
2 a $\frac{729}{9} = 81 = 3^4$ **b** $\frac{6561}{243} = 27 = 3^3$
3 a 2^8 **b** 2^{11} **c** 2^6 **d** 2^3

Investigation: Polyominoes

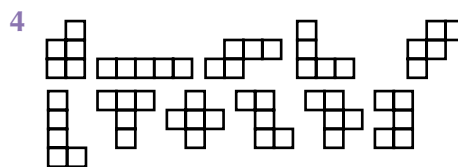
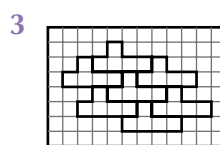
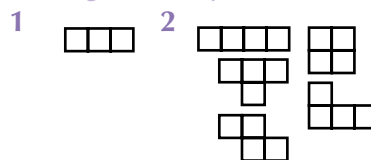

- 5 a** 27
b No, the formula is not correct. There are 35 different hexominoes

Algebra and Number Patterns 6

9M Index laws with algebraic terms

- 1 a** c^5 **b** x^2 **c** p^2q^2
 d r^3s^2 **e** ab^3c^2
2 a $y \times y \times y$
b $w \times w \times w \times w \times w \times w$

Homework Book Answers

- c $x \times y \times y \times y$
 d $x \times x \times x \times y$
 e $p \times p \times p \times p \times q \times q$
- 3 a $4g^4w^2$ 4 baabaa
 5 a w b 1
 6 a $4x^2$ b $30y^2$ c $2p^2$
 d $30x^2$ e $8q^3$ f $8x^2$
 g $6y^3$ h $8x^2$ i $6pq$
 j $30x^2y^2$
 7 a x^6 b p^5 c x^4
 d x^3 e p^6 f x^6
 g x^6 h a^5 i p^{12}
 j x^{10}
 8 a $6x^9$ b $12p^5$ c $14x^3$
 d $4x^5$ e $16y^5$ f $30x^3$
 g $7x^3$ h $6p^3$ i $5x^5$
 j $12x^4$
 9 a x^2 b p^9 c y
 d x^4 e y^3 f q
 10 a $2x^2$ b $5x^2$ c $5p$
 d $7x^2$ e $\frac{4x^2}{3}$ f $\frac{3p}{2}$
 g $\frac{x^8}{2}$ h $\frac{2x^2}{3}$ i $\frac{x^6}{4}$

Algebra and Number Patterns 7

9N Managing brackets: Other index laws

- 1 a a^3b^3 b $\frac{g}{h^6}$
 2 a p^{10} b q^6
 c $49p^8$ d $81x^8$
 3 a $x^{20}y^5$ b $49x^4$
 c $9x^4y^6$ d $8x^6y^3$
 4 a $\frac{x^{15}}{y^6}$ b $\frac{8x^6}{y^3}$
 c x^{10} d $\frac{9xy^3}{2}$

9O Exploring scientific notation

- 1 a 3.62×10^1 b 6.137×10^2
 c 7.3×10^0 d 6×10^2
 e 1.355×10^3 f 6.77×10^5
 g 4.4187×10^1 h 2.9×10^7
 2 a 111.9 b 8400
 c 3.6 d 55 600
 e 63.12 f 48 800 000
 g 371.68 h 2070
 3 5×10^5
 4 a two hundred and forty-five million years ago
 b 2.45×10^8 years
 5 a $1\,400\,000\,000 \text{ km}^3$ b 2.65×10^{11} litres
 6 1.209×10^{24}

- 7 a 4.5×10^{-3} b 1.103×10^{-2}
 c 7×10^{-1} d 7.81×10^{-9}
 8 a 0.56 b 0.004 4432
 c 0.000 0018 d 0.0903
 9 2.5×10^{-2} 10 0.001 mm
 11 a 7.8×10^1 b 7.8×10^{-3}
 c 7.8×10^0 d 7.8×10^4
 12 a 0.000 39 b 3900
 c 0.39 d 39
 13 1.09×10^{-1} , 1.9×10^{-1} , 1.99×10^{-1} , 1.9×10^0 , 1.09×10^1

Chapter 10

Solving Linear Equations 1

10A Simple equations

- 1 a $x = -3$ b $x = 3$ c $x = -5$
 d $x = 0$ e $x = -5$ f $x = -1$
 2 a $x = -3$ b $y = 2$ c $x = -6$
 d $y = 8$ e $y = 18$ f $x = -4$
 3 a $x = -48$ b $x = -24$ c $x = 15$
 d $x = -2$ e $y = 5$ f $x = -25$
 4 a $x - 8 = -19$ b $x + 30 = -22$ c $-4x = -28$
 d $\frac{x}{12} = -5$
 5 $\frac{x}{4} = 132$

Puzzle

The batteries cost \$2

Puzzle: What did the bald man say?

'Hair today gone tomorrow'

10B Solving equations using backtracking

- 1 a $x = 1$
 $\boxed{x} \xrightarrow{-3} \boxed{x-3}$
 $=$
 $\boxed{1} \xleftarrow{+3} \boxed{-2}$
 b $x = -8$
 $\boxed{x} \xrightarrow{+10} \boxed{x+10}$
 $=$
 $\boxed{-8} \xleftarrow{-10} \boxed{2}$
 c $x = -3$
 $\boxed{x} \xrightarrow{\times -4} \boxed{-4x}$
 $=$
 $\boxed{-3} \xleftarrow{\div -4} \boxed{12}$
 d $x = 27$
 $\boxed{x} \xrightarrow{\div -3} \boxed{\frac{x}{-3}}$
 $=$
 $\boxed{27} \xleftarrow{\times -3} \boxed{-9}$

2

$$\begin{array}{c} \boxed{x} \xrightarrow{\times 3} \boxed{3x} \xrightarrow{+22} \boxed{3x+22} \\ = \\ \boxed{-5} \xleftarrow{\div 3} \boxed{-15} \xleftarrow{-22} \boxed{7} \\ x = -5 \end{array}$$

3 a

$$\begin{array}{c} \boxed{x} \xrightarrow{\times 10} \boxed{10x} \xrightarrow{-2} \boxed{10x-2} \\ = \\ \boxed{-1} \xleftarrow{\div 10} \boxed{-10} \xleftarrow{+2} \boxed{-12} \\ x = -1 \end{array}$$

b

$$\begin{array}{c} \boxed{x} \xrightarrow{\times 2} \boxed{2x} \xrightarrow{+19} \boxed{2x+19} \\ = \\ \boxed{-15} \xleftarrow{\div 2} \boxed{-30} \xleftarrow{-19} \boxed{-11} \\ x = -15 \end{array}$$

Solving Linear Equations 2

10C Inverse operations

- 1 a $x = -5$ b $x = 3$ c $x = -4$
 d $x = -21$ e $x = 16$ f $x = -24$
 g $x = -19$ h $x = -28$
- 2 a $x = -8$ b $x = -2$ c $x = -1$
 d $x = -4$ e $x = 2$ f $x = -14$
 g $x = -24$ h $x = -27$

10D Solving multi-step equations

- 1 a $x = 3$ b $x = 10$ c $x = -7$
 d $x = -1$ e $x = -8$ f $x = -1$
 g $x = -5$ h $x = -7$
- 2 a $x = -8$ b $x = 8$ c $x = 6$
 d $x = -18$
- 3 a $x - 13 = -6$ $x = 7$
 b $-8x + 15 = -1$ $x = 2$
- 4 a **B:** $4x + 3 = 39$ b $x = 9$
- 5 a $2x + 3 = 19$ b $x = 8$ km

Solving Linear Equations 3

10E Solving equations with brackets

- 1 a $x = 5$ b $x = -13$ c $x = 2$ d $x = 1$
- 2 a $2(n-5) = 48$
 $2n - 10 = 48$
 b 29

10G Using the substitution method

- 1 a $x = 2$ and $y = 9$
 b $x = 10$ and $y = 2$
 c $x = 0$ and $y = -1$
 d $x = -3$ and $y = 10$

10H Using the elimination method 1

- 1 a $x = 4$ and $y = 6$
 b $x = 16$ and $y = 5$
 c $x = -1$ and $y = 3$

2 a $x = 4$ and $y = 3$

b $x = 5$ and $y = 6$

c $x = 7$ and $y = -1$

d $x = 6$ and $y = \frac{-1}{2}$

Puzzle:

1 spider and 3 flies

Solving Linear Equations 4

10H Using the elimination method 2

- 1 a $x = 2$ and $y = 6$
 b $x = 8$ and $y = -1$
 c $x = 10$ and $y = -2$
 d $x = 9$ and $y = -2$

10J Applying simultaneous equations

- 1 a $x + y = 87$
 $x - y = 29$
 b $x = 58, y = 29$
- 2 a The total number of wheels fitted to all the Xplorer prams is $4x$.
 b $x = 13$ and $y = 7$. There were 13 Xplorer prams and 7 Youngster prams made that day.
- 3 a $x + y = 10$
 b $50x + 70y = 580$
 c There are 6 standard units and 4 family units.
- 4 a $15y$ represents the wages paid to the staff members.
 b The wages are paid out by the school. $8x$ is income, whereas $15y$ is an expense.
 c There are 19 children at the lesson.

Investigation: Treasures Baby Club Points

- 1 Two 5-point tokens and one 6-point token
 2 No, no
 3 19 points

Chapter 11

Linear Graphs 1

11A Plotting points on the Cartesian plane

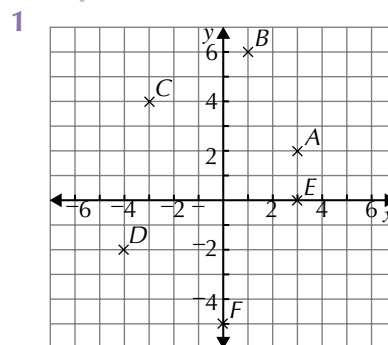

- 2 A = (1, 3) B = (3, 1) C = (-4, -2) D = (-3, 5)
 E = (-2, 0) F = (5, -3) G = (0, 6) H = (0, 0)
- 3 a {A, B, C} b {G, H, I} c {D, E, F}
- 4 The shape is a star. 5 False

Homework Book Answers

Puzzle

Green peas

Puzzle

False. It is not possible to draw an equilateral triangle whose corners lie on a square grid with whole number coordinates.

11B Linear patterns and simple rules

1 a $(-3, -1)$ $(-2, 0)$ $(-1, 1)$ $(0, 2)$ $(1, 3)$ $(2, 4)$ $(3, 5)$

$y = x + 2$

b $(-1, -3)$ $(0, 0)$ $(1, 3)$ $(2, 6)$

$y = 3x$

c $(-2, 4)$ $(-1, 2)$ $(0, 0)$ $(1, -2)$ $(2, -4)$

$y = -2x$

2 a $y = x + 8$ b $y = x - 3$ c $y = -3x$

Linear Graphs 2

11D Plotting lines using a rule

1 a

Time (hours)	Battery current (amps)
0	30
1	25
2	20
3	15

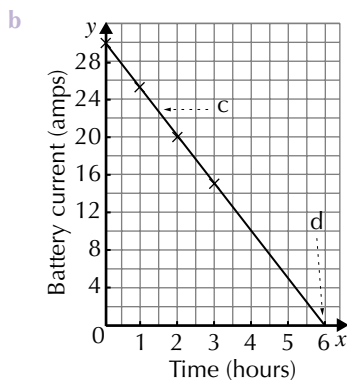

c 22.5 amps d 6 hours e C: $B = 30 - 5t$

2 a \$3 b \$9 c \$4.50

d 6 tickets e You can buy 4 tickets for \$6.

f B: (10, 15)

g No. The number of tickets must be a whole number—you can't have two and a half tickets.

11E Horizontal and vertical lines

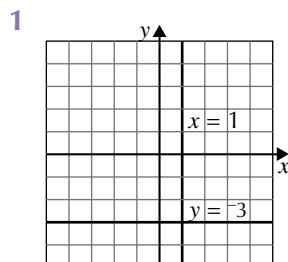

2 a: $y = -1$ b: $x = 2$

3 a false b false c true

4 a $y = 9$ b $x = -2$

11F Gradients of straight lines

1 a 1 b $\frac{1}{3}$ c 2

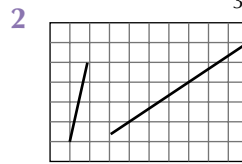

3 $\{\frac{1}{5}, \frac{1}{2}, 1, 2, 3\}$

4 0 5 a -2 b $-\frac{1}{3}$ c -1

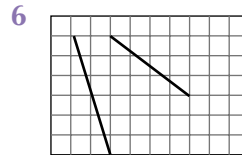

7 $\{-\frac{1}{3}, -\frac{4}{5}, -1, -2, -4\}$

Linear Graphs 3

11G Finding equations of lines from graphs

1

Rule	Gradient	Vertical intercept
a $y = 4x + 5$	4	5
b $y = 3x - 1$	3	-1
c $y = x + 6$	1	6
d $y = 0.5x + 1$	0.5	1
e $y = 6x - 4$	6	-4
f $y = 2x$	2	0

2 a $y = 2x + 4$ b $y = 6x - 1$

c $y = 2x$ d $y = x - 2$

3 First graph: gradient: 3 y-intercept 3
general rule $y = 3x + 3$

Second graph: gradient: 2 y-intercept -3
general rule $y = 2x - 3$

4 a 1.5 litres per hour

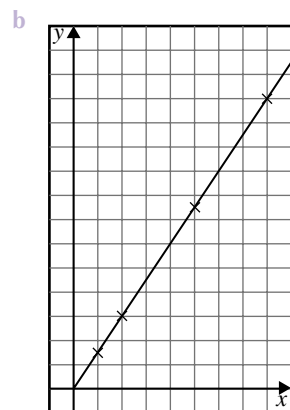

c $\frac{3}{2}$ or 1.5

d $y = \frac{3}{2}x$ or

$y = 1.5x$

e 2 hours 40 minutes

11I The gradient and y-intercept

1 a 3 b $\frac{2}{5}$ c -2

2 a -1 b 6 c 3

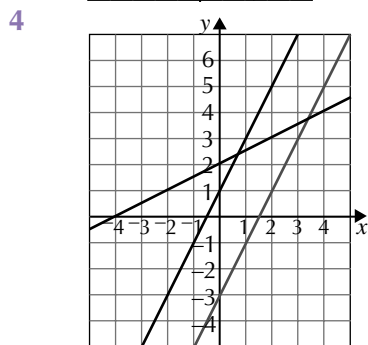
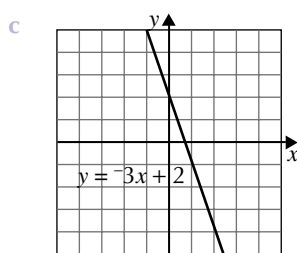
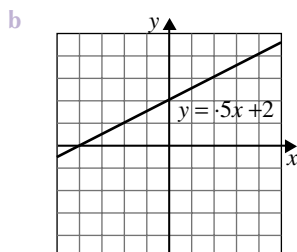
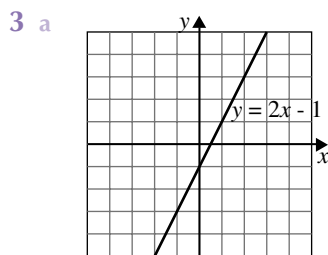

- 5 a The gradients will be the same.
 b Steeper lines have bigger gradients.
 c The line cuts the y-axis above (0, 0) if the y-intercept is positive and cuts the y-axis below (0, 0) if the y-intercept is negative
 6 a 6. This represents the height of the candle when it is first lit.
 b decreases by $\frac{3}{4}$ cm
 c The point (6, 0) does not lie on the graph. However no more candle is left after 8 hours – it can't keep burning.

Chapter 12

Quadratic Functions 1

12A Quadratic equations

- 1 a $x = 1$ or $x = 2$ b $x = -4$ or $x = 3$
 c $x = -7$ or $x = -12$ d $x = 1$ or $x = -13$
 e $x = -4$ f $x = 1$ or $x = -7$
 g $x = 0$ or $x = 7$ h $x = 5$ or $x = 2$
 i $x = 0$ or $x = -3$
 2 a $x = -3$ or $x = \frac{3}{2}$ b $x = -\frac{5}{2}$ or $x = 6$

c $x = \frac{1}{2}$ or $x = -\frac{2}{3}$ d $x = -\frac{1}{4}$ or $x = \frac{1}{4}$

e $x = -\frac{5}{3}$ f $x = 0$ or $x = 3$

g $x = 0$ or $x = -4$ h $x = 0$ or $\frac{1}{8}$

3 a $x = 1$ or $x = 2$ b $x = -6$ or $x = 2$

c $x = -2$ or $x = -5$ d $x = 6$ or $x = -5$

e $x = 3$ or $x = 2$ f $x = 2$ or $x = -3$

g $x = -5$ h $x = 8$ or $x = -8$

4 a $x = 0$ or $x = -5$ b $x = 0$ and $x = 3$

c $x = 0$ or $x = \frac{7}{3}$ d $x = 4$ or $x = -2$

5 a $x = -9$ or $x = 5$ b $x = 5$ or $x = -3$

c $x = 3$ d $x = 0$ or $x = 7$

e $x = 3$ or $x = -3$

6 a $x = 2$ or $x = -2$ b $x = 0$ or $x = -8$

c $x = 8$ or $x = 2$ d $x = 4$ or $x = 1$

e $x = 2$ or $x = -10$ f $x = 9$ or $x = 0$

Investigation: The Christmas tree

- 1 1, 4, 9, 16
 2 1, 4, 9, 16, 25
 3 1, 4, 9, 16, 25, 36, 49, 64, 81, 100
 4 90
 5 Only lights that have a perfect square number stay on

Quadratic Functions 2

12B Worded problems

- 1 a $x^2 - 12 = 4x$ or $x^2 - 4x - 12 = 0$
 b $x = 6$ or $x = -2$
 2 a $(x + 8)^2 = x + 20$ or $x^2 + 15x + 44 = 0$
 b $x = -11$ or $x = -4$
 3 $x(x + 5) = 36$
 $x^2 + 5x - 36 = 0$
 $(x + 9)(x - 4) = 0$
 $x = -9$ or $x = 4$
 The pairs of numbers are 4 and 9, or -4 and -9
 4 $x^2 + (x + 4)^2 = 40$
 $x^2 + x^2 + 8x + 16 = 40$
 $2x^2 + 8x - 24 = 0$
 $x^2 + 4x - 12 = 0$
 $(x - 2)(x + 6) = 0$
 $x = 2$ or $x = -6$
 The two numbers are either 2 and 6, or -2 and -6

APPLICATIONS

- 5 a 4 km
 b The life raft drifts out to sea so that after 1 hour it is 6 km from the estuary.
 c $x = 4$ or $x = -1$
 d The life raft will have drifted back to the estuary 4 hours after the dinghy sank.
 6 $(x - 2)(x - 5) = 54$
 $x^2 - 7x + 10 = 54$
 $x^2 - 7x - 44 = 0$

Homework Book Answers

$$(x - 11)(x + 4) = 0$$

$$x = 11 \text{ or } x = -4$$

The photograph measured 11 cm \times 11 cm before it was cropped

7 a The x represents Karen's age.

b $x^2 + 4x + 22 = 9x + 36$

$$x^2 - 5x - 14 = 0$$

c $(x - 7)(x + 2) = 0$

$$x = 7 \text{ or } x = -2$$

Karen is 7, and Lionel is 11.

8 a $(2x - 3)(x - 2) = x^2$

$$2x^2 - 7x + 6 = x^2$$

$$x^2 - 7x + 6 = 0$$

b $(x - 6)(x - 1) = 0$

$$x = 6 \text{ or } x = 1$$

$x = 6$ is the only realistic answer in this situation.

The combined area of both rugs is 72 m²

9 $(2x + 4)(2x + 6) - 24 = 56$

$$4x^2 + 20x + 24 - 24 = 56$$

$$4x^2 + 20x - 56 = 0$$

$$x^2 + 5x - 14 = 0$$

$$(x + 7)(x - 2) = 0$$

$$x = -7 \text{ or } x = 2$$

$x = 2$ is the only realistic answer in this situation.

The width of the walkway is 2 m.

Quadratic Functions 3

12C Plotting parabolas

1

x	y	Co-ordinates
-2	3	(-2, 3)
-1	0	(-1, 0)
0	-1	(0, -1)
1	0	(1, 0)
2	3	(2, 3)

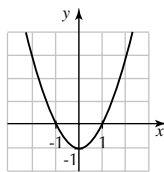

2

x	y	Co-ordinates
-2	1	(-2, 1)
-1	0	(-1, 0)
0	1	(0, 1)
1	4	(1, 4)
2	9	(2, 9)

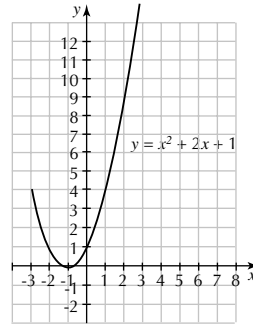

12D Key features of quadratic functions

1 a axis of symmetry: $x = 2$

turning point: (2, -1)

y-intercept: (0, 3)

x-intercepts: (1, 0) (3, 0)

b axis of symmetry: $x = 1$

turning point: (1, -1)

y-intercept: (0, 0)

x-intercepts: (0, 0) (2, 0)

c axis of symmetry: $x = 2$

turning point: (2, 0)

y-intercept: (0, 4)

x-intercept: (2, 0)

d axis of symmetry: $x = 3$

turning point: (3, 9)

y-intercept: (0, 0)

x-intercepts: (0, 0) (6, 0)

2 a $y = x^2 + 2$

x	-2	-1	0	1	2	3
y	6	3	2	3	6	11

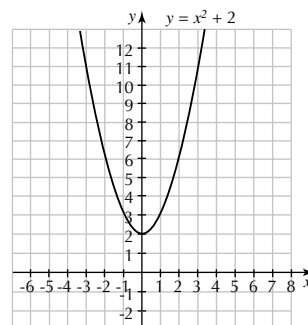

axis of symmetry: $x = 0$

turning point: (0, 2)

y-intercept: (0, 2)

x-intercepts: none

b $y = x^2 + 2x$

x	-3	-2	-1	0	1	2
y	3	0	-1	0	3	8

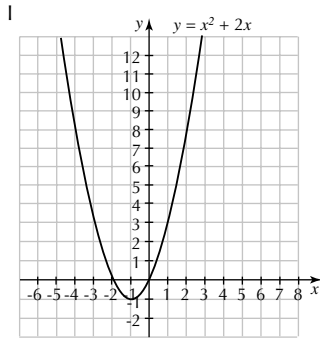

axis of symmetry: $x = -1$
 turning point: $(-1, -1)$
 y-intercept: $(0, 0)$
 x-intercepts: $(-2, 0)$ $(0, 0)$

c $y = (x - 1)^2$

x	-2	-1	0	1	2	3
y	9	4	1	0	1	4

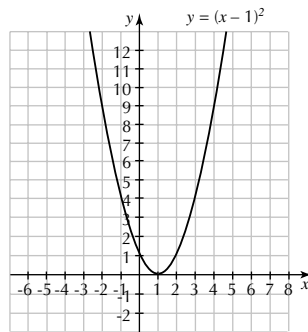

axis of symmetry: $x = 1$
 turning point: $(1, 0)$
 y-intercept: $(0, 1)$
 x-intercept: $(1, 0)$

Quadratic Functions 4

12F Exploring parabolas: $y = ax^2$, a is positive

- 1 When the number in front (a) is greater than 1 the parabola is narrow and steep compared with the basic $y = x^2$ parabola. When the number in front is less than 1 the parabola is wider and not very steep.

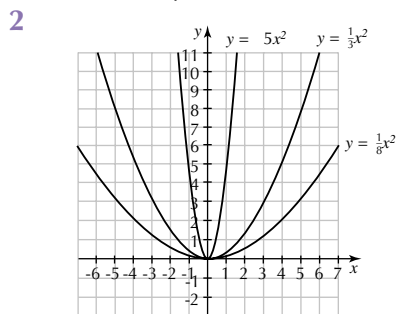

- 3 $(0, 0)$

12G Exploring parabolas: $y = ax^2$, a is negative

- 1 A negative number in front of x^2 gives an upside-down parabola.

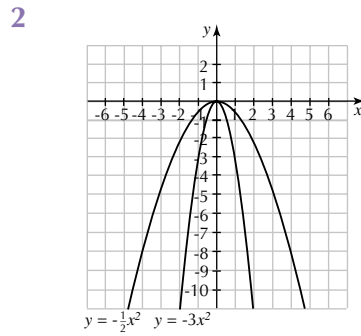

12H Exploring parabolas: $y = ax^2 + k$

- 1 Adding a number moves the parabola upwards by that number of units, and subtracting a number moves the parabola downwards.

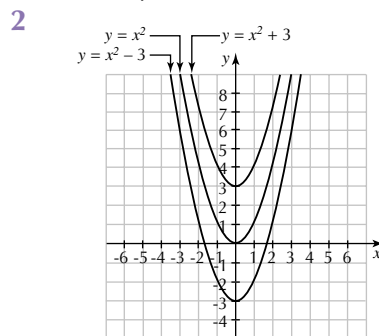

- 3 a $(0, 3)$ b $(0, 0)$ c $(0, -3)$

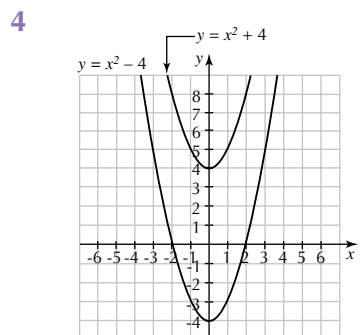

- 5 a $a: y = x^2 + 4$ b $(2, 0)$ $(-2, 0)$

- 6 a The turning points are the points $(0, 4)$ and $(0, -4)$.

- 7 a $(0, 5)$ b $(0, -10)$

- c $(0, 2)$

12I Exploring parabolas: $y = a(x - h)^2$

- 1 Adding a number inside the brackets moves the parabola to the left by that number of units. Subtracting a number inside the brackets moves the parabola to the right by that number of units.

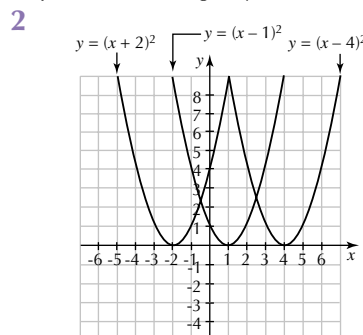

Homework Book Answers

- 3 A parabola of the form $y = (x - h)^2$ always has one x -intercept and one y -intercept.

Quadratic Functions 5

12] Sketching parabolas

- 1 a $x = 2$ and $x = -5$
(that is, co-ordinates are (2, 0) and (-5, 0))
b $x = -1$ and $x = 7$
(that is, co-ordinates are (-1, 0) and (7, 0))
c $x = 0$ and $x = 3$
(that is, co-ordinates are (0, 0) and (3, 0))
d $x = 1$ and $x = 2$
(that is, co-ordinates are (1, 0) and (2, 0))
- 2 a $y = -10$ (that is, co-ordinates are (0, -10))
b $y = -7$ (that is, co-ordinates are (0, -7))
c $y = 0$ (that is, co-ordinates are (0, 0))
d $y = 2$ (that is, co-ordinates are (0, 2))

3

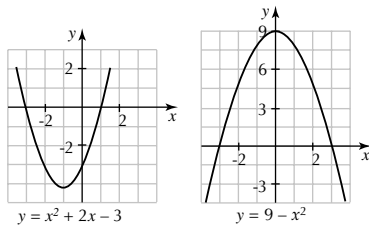
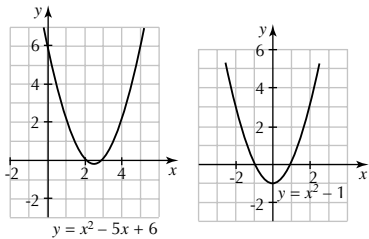
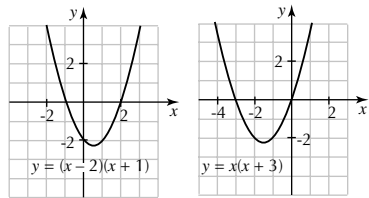

- 4 a $y = (x - 3)(x + 1)$ or $y = x^2 - 2x - 3$
b $y = x(x - 2)$ or $y = x^2 - 2x$
- 5 a $y = (x + 2)(x - 6)$ or $y = x^2 - 4x - 12$
b (2, -16)
- 6 The other intercept occurs at $x = 6$, the point (6, 0.)
- 7 a $y = 1 - x^2$ b $y = x^2 + 1$
c $y = (x + 1)^2$ d $y = (x - 1)^2 + 1$
e $y = x(x - 2)$ f $y = -(x - 1)^2$

8 a

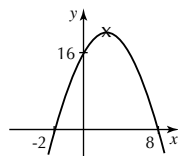

- b The price of a box of toffee cannot be negative. (If it were, they would be paying the people to take the toffee.)

- c \$0 to just under \$8 d The value of y at the turning point of the graph gives the value of the maximum profit (see the graph).
e A price of \$3 per box produces the most profit.
f \$25

Chapter 13

Chance 1

3B Sample space grids

1 a

		Second die			
		1	2	3	4
First die	1	2	3	4	5
	2	3	4	5	6
	3	4	5	6	7
	4	5	6	7	8

- b $\frac{1}{4}$ c $\frac{1}{16}$ d 0 e 1

2 a

		Gayle			
		50c	\$1	\$1	\$2
Henry	20c	70c	\$1.20	\$1.20	\$2.20
	\$2	\$2.50	\$3	\$3	\$4
	\$2	\$2.50	\$3	\$3	\$4

- b i $\frac{1}{6}$ ii $\frac{1}{2}$ iii 0

Investigation: the crooked cricket captain

It is more likely that the sum of the number of fingers will be even than the sum will be odd. The two probabilities are $\text{Pr}(\text{even}) = \frac{13}{25}$ and $\text{Pr}(\text{odd}) = \frac{12}{25}$

13C Tree diagrams

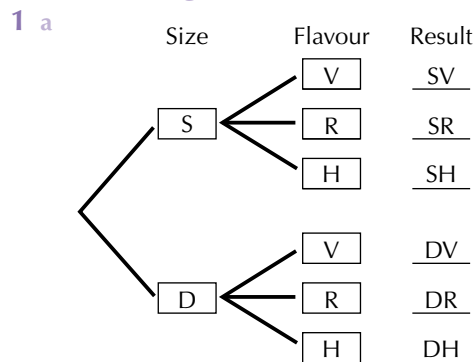

b 6

c

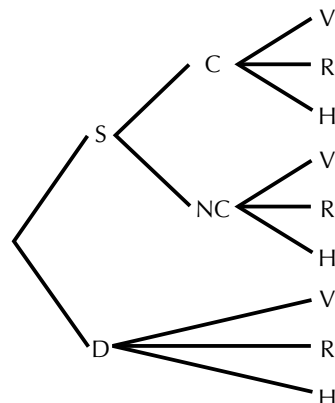

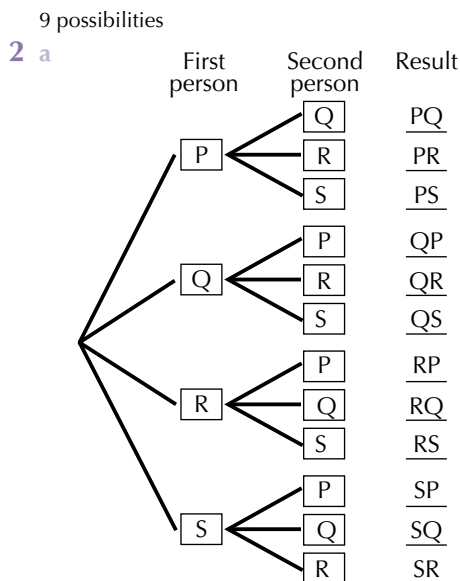

- b There are 12 possibilities if drawing a first lot is considered a different outcome from being chosen in the second draw. c 6
- d $\Pr(\text{one boy and one girl}) = \frac{2}{3}$ so it is a likely outcome.

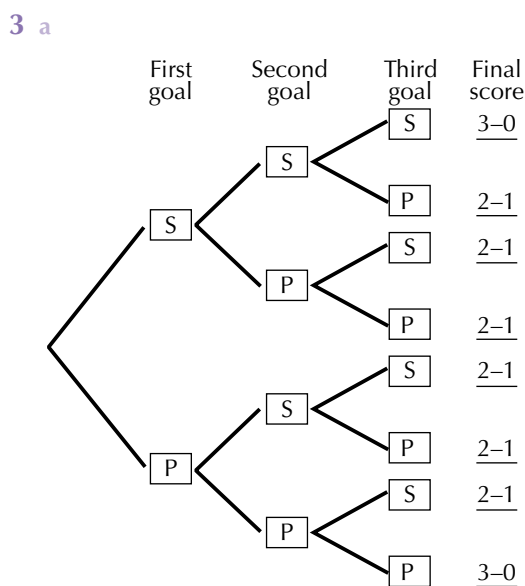

b 2-1

Chance 2

13D Exploring a deck of cards

- 1 a $\frac{1}{2}$ b $\frac{1}{4}$ c $\frac{1}{52}$ d $\frac{3}{4}$
- e $\frac{1}{13}$ f $\frac{9}{13}$ g $\frac{4}{13}$ h $\frac{1}{13}$

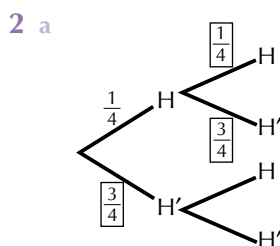

b $\frac{1}{16}$

13F Estimating proportions using sampling

- 1 a 54% b 648
- 2 Approximately 6 times.
- 3 About 27 times. 4 40

13G Extension: Venn diagrams 1

- 1 a true b true c false d true
- 2 a {NSW, NT, QLD, SA, TAS, VIC, WA}
- b {NSW, QLD, TAS, VIC}
- c 4 d {QLD}

Chance 3

13G Extension: Venn diagrams 2

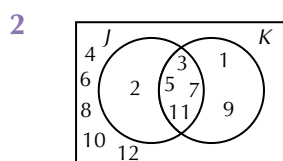
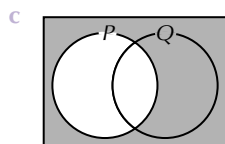
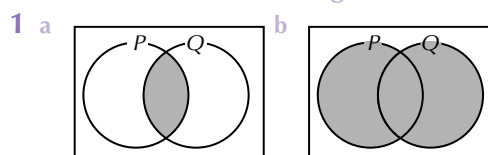

- 3 a $K = \{1, 2, 4, 5, 8, 10, 20, 40\}$
- b 32
- c $J \cap K = \{2, 4, 8, 10, 20, 40\}$
- 4 a $N = \{1, 3, 9\}$
- b $N' = \{2, 4, 5, 6, 7, 8\}$
- c $\{\}$

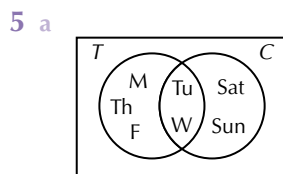

- b Saturday, Sunday
- c $C \cap T$ represents the days he travels on the train and in the car

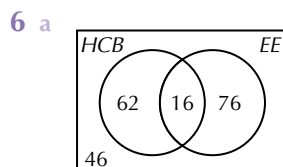

- b 16 c 62

13H Extension: Sets and probability

- 1 a $\frac{5}{26}$ b $\frac{4}{13}$
- 2 a $\frac{7}{20}$ b $\frac{1}{2}$ c $\frac{2}{5}$ d $\frac{3}{10}$ e $\frac{3}{4}$

Homework Book Answers

3 a 28 b 17 c 7 d $\frac{3}{7}$ e $\frac{1}{7}$

4 $\frac{5}{8}$

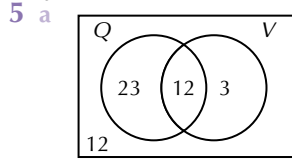

b i $\frac{7}{10}$ ii $\frac{6}{25}$ iii $\frac{7}{10}$
c $\frac{6}{25}$

Chapter 14

Statistics 1

14A Collecting numerical data

1 a 5 b 3
c 4 and 8 d 99
e No, the result of tossing this die would always be a whole number.

2 a 8 b 23
c 85 d 206

14B Column graphs and histograms

1 a 4 b 5 c 22
d We cannot tell exactly how long in the interval 2-3 minutes those 5 people had been waiting.

2 a

Weight interval (kg)	Frequency
18 - 22	4
23 - 27	3
28 - 32	5
33 - 37	4
38 - 42	1
43 - 47	3

b 7

c

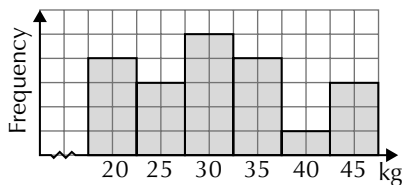

Statistics 2

14C The median, range and IQR

1 a 20 b 6.5
2 a 16 b 171
3 a $Q_1 = 32.5$, $Q_3 = 51$, interquartile range = 18.5
b $Q_1 = 5.5$, $Q_3 = 9.5$, interquartile range = 4
4 a 13 seconds
b $Q_1 = 60$ seconds, $Q_3 = 66$ seconds
c 6 seconds
5 a $Q_1 = \$77$, $Q_3 = \$120$
b Range = \$255, Inter-quartile range = \$43
c He will look at those between \$120 and \$77 in price

14D Stem-and-leaf graphs

1 Scores in golf tournament

6	8 9
7	1 1 3 6 7 7
8	0 1 2 3 4 5 5 8
9	1 2 2
10	5

2 a 135 b 125.5

c i 86 ii 106
iii 135 iv 29

3 a 94

b median = 110, $Q_1 = 101$, $Q_3 = 114$

c 5 d 114

4 a 47.5 for, 56 against

b i The team must have won the game in which it conceded 29 goals because it scored more than 29 in each of its games.
ii 7

Statistics 3

14E The mean

1 a 30 b 6.375
2 a 319.25 b 331 c mean d 17 000
3 a mode b the mean; the number of coins
4 a 54 minutes b \$2.80

14G Scattergraphs

1 In general, the taller a person is, the further they can long-jump.

2 a US\$1700

b USA

c France

d Any four countries from Netherlands, Iceland, Belgium, Norway and Luxembourg have about the same health expenditure per person as Australia.

e The higher GDP per person, the more that is spent on health per person - 'rich countries spend more on health per person'.

f US\$800

3 a 2

b

Number of siblings	Frequency	$x \times f$
0	2	0
1	7	7
2	8	16
3	7	21
4	0	0
5	2	10
Totals	26	54

c The mean = $\frac{\text{The total number of siblings}}{\text{Number of children}} = \frac{x \times f}{f}$
 $= \frac{54}{26} = 2.077$

The mean number of siblings per student is 2.077.